



pelican systems



## FireWALL 102/60/6m

Pelican Systems JUMBO® FireWALL 102/60/6m with overall thickness of 156mm, with 102 x 35mm x 0.6 JUMBO® Studs at 400mm centres friction fitted into Head Track, Middle Track and Floor Track. The framework will be installed in two sections to create an H-Track/Transom at three meters, this will consist of two 103mm x 24mm x 0.6 JUMBO® Tracks fixed back-to-back with Wafer Tek Screws 4.2 x 13, alternately fixed in two lines at 300mm centres. The framework will be cladded on both sides with a double layer of Fire-Resistant JUMBO® Plasterboard at 220mm centres using 25mm JUMBO® Screws on the 15mm Fire-Resistant Base Layer and 41mm JUMBO® Screws on the 12mm Fire-Resistant Face Layer. All plasterboard joints are to overlap and be staggered and fixed with no joints forming on the H-Track/Transom. At all the 1200mm Plaster Joints fix a Galvanized Back Plate of 1300mm x 50mm x 0.5mm to create a fixing space for the drywall screws at intervals of 220mm. All joints to be covered with JUMBO® Fibre Tape and finished with two layers of JUMBO® Jointing Plaster applied and lightly sanded down, leaving wall surface prepared for painting, all in accordance with the supplier's recommendations.

### Typical Illustration for JUMBO® FireWALL 102/60/6m

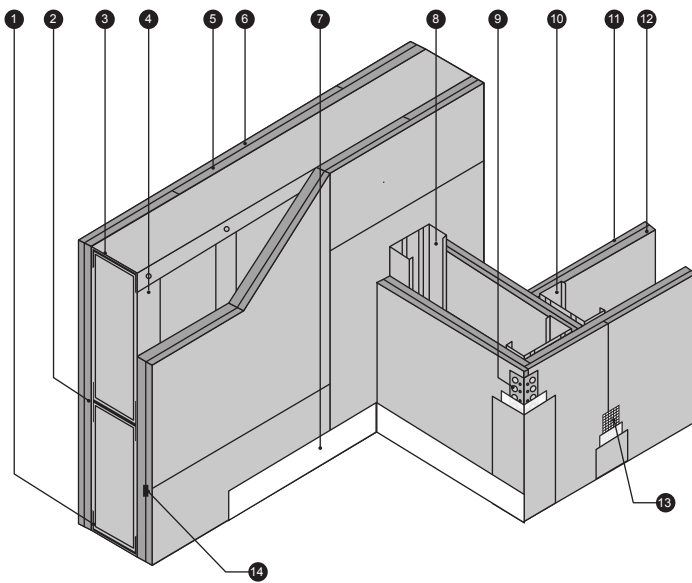

1. JUMBO® 103mm Track
2. JUMBO® 103mm H-Track
3. JUMBO® 103mm Track
4. JUMBO® 102mm Stud
5. JUMBO® 15mm FR Plasterboard
6. JUMBO® 12mm FR Plasterboard
7. JUMBO® Skirting
8. JUMBO® 102mm Stud
9. JUMBO® Steel Corner Bead
10. JUMBO® 102mm Stud
11. JUMBO® 12mm FR Plasterboard
12. JUMBO® 15mm FR Plasterboard
13. JUMBO® Fibre Tape
14. 1300 x 50 x 0.5 Steel Backing Plate

**Note: Stud spacings are at 400mm centres**

### Validity and Application of the Test Report

Fire rated systems need to be assembled strictly in accordance with the relevant test reports, and approved system details and specifications. If not, the fire resistance could be compromised and the test result cannot be applied.

The test can be applied to JUMBO® FireWALLS up to 6 metres in height.

The following information is available on our website:-

BOQ Specification, Data Sheets, Revit Files and Detail Drawings.