



## T2 Toilet partitions

frameless partition system

The design and functionality of the T2 Toilet Partition System was inspired by the need for an upmarket, durable yet vandal resistant toilet partition system that can be used in a variety of public facility applications such as washroom cubicles, ablution cubicles and change room cubicles.

The T2 system is a frameless panel system constructed with 12mm high pressure laminate board. The product is superior in quality and is targeted at the high end of the market but still remains a cost efficient solution.

T2 is ideal for use in Shopping Malls, Stadiums, Hotels, Conference Facilities and Educational Institutions

### Features and Benefits:

- Neat and hygienic
- Double sided facings which are water resistant
- Frameless with superior aesthetics
- Stylish stainless steel ironmongery
- Variety of colours options available including woodgrains
- Low maintenance and user friendly system
- Vandal resistant and rodent proof
- Height adjustable feet system

### Innovative Design and Superior Aesthetics



1. Indicator lock back
2. Indicator lock surface
3. Corner fastener
4. Hinge
5. Clothes hook
6. Adjustable leg

T2 PLAN SHOWING FIXING DETAIL

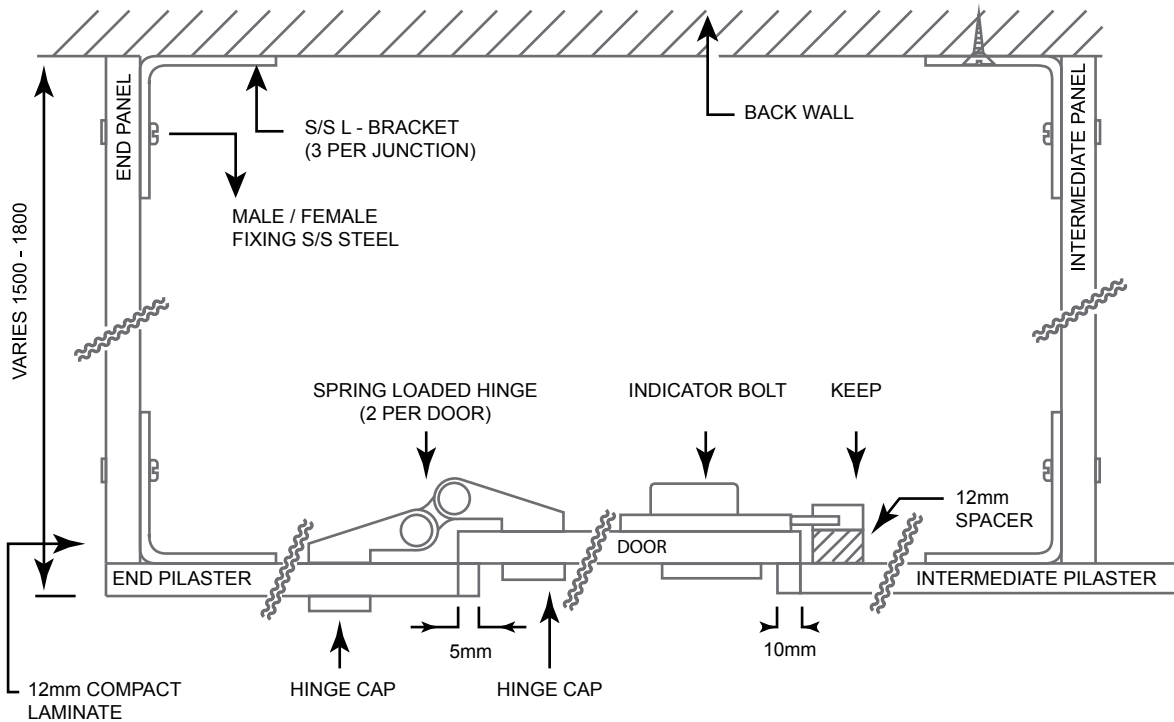

T2 FRONT ELEVATION

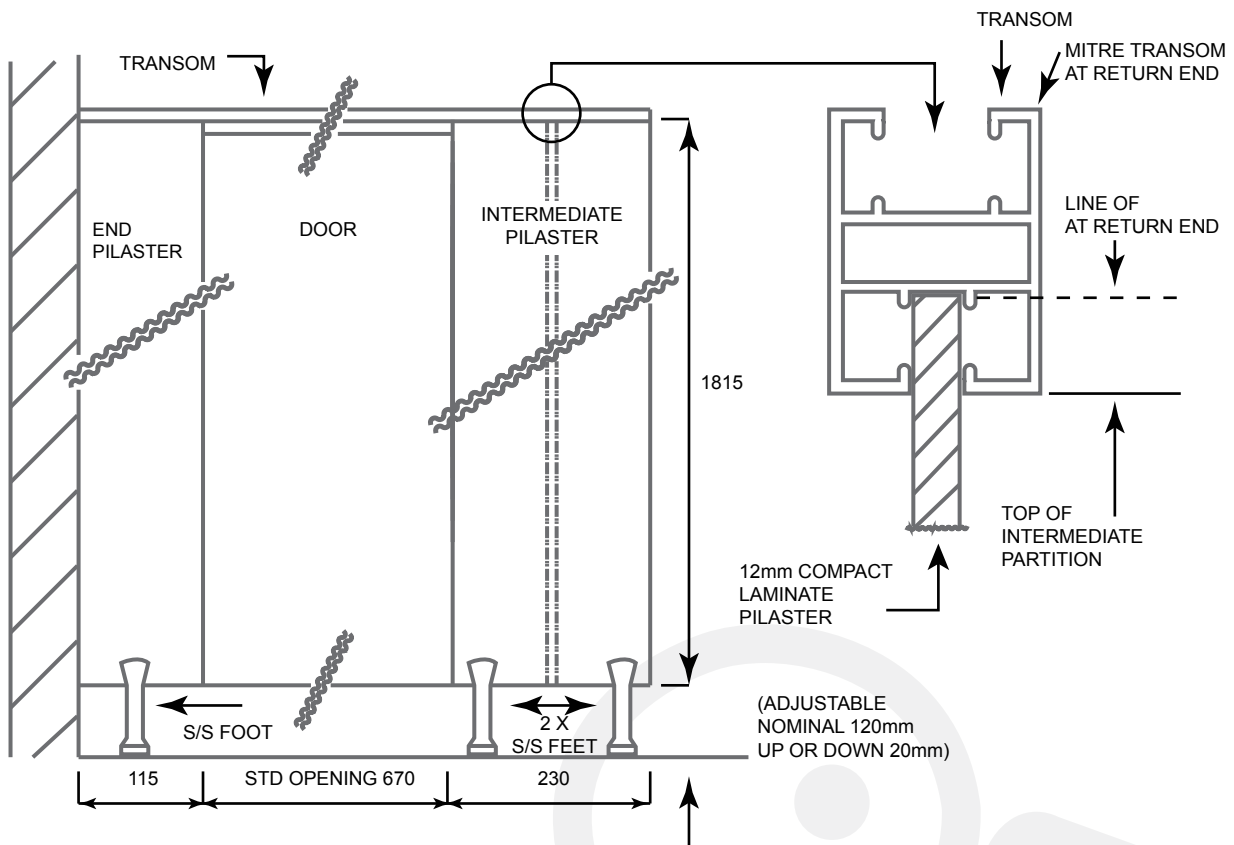

**Bill of quantity specification:**

Supply and install Pelican Systems T2 Toilet Partition System comprising of 12mm thick Compact HPL panels (specify finish), supported by overhead bracing with grade 304 stainless steel supporting feet, plugged and screwed to floor and fixed into position by means of grade 304 stainless steel wall fixing brackets plugged and screwed to walls.

Partition doors: 762 x 1762mm high doors including standard ironmongery comprising of indicator bolts, hat and coat hooks, door stops, toilet roll holders and buffers.