



pelican systems

FireWALL 63/60/4.2m



Pelican Systems JUMBO® FireWall 63/60 with overall thickness of 93mm, with 63 x 35mm JUMBO® Studs at 600mm centres friction fitted into head track and floor track and clad on both sides with a single layer of 15mm thick Fire Resistant JUMBO® Board fixed at 220mm centres using 25mm Drywall Screws. All exterior joints to be covered with JUMBO® Tape and finished with two layers of JUMBO® Jointing Plaster applied and lightly sanded down, leaving wall surface prepared for painting, all in accordance with the supplier's recommendations.

Typical Illustration for JUMBO® FireWALL 63/60/4.2m

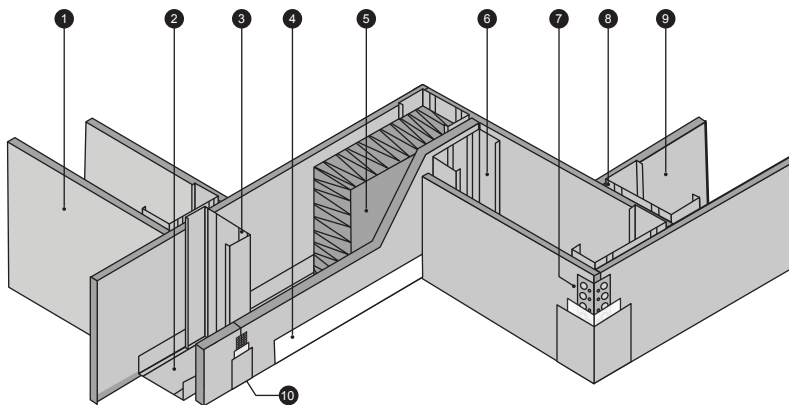

1. JUMBO® 15mm FR Plasterboard
2. JUMBO® 64mm Track
3. JUMBO® 63mm Stud
4. JUMBO® Skirting
5. JUMBO® 63mm SoundTherm (not part of test / optional)
6. JUMBO® 63mm Stud
7. JUMBO® Corner Bead
8. JUMBO® 63mm Stud
9. JUMBO® 15mm FR Plasterboard
10. JUMBO® Tape

Note: 63/60 - No Insulation
63/60/S44 - With SoundTherm

Validity and Application of the Test Report

Fire rated systems need to be assembled strictly in accordance with the relevant test reports, and approved system details and specifications. If not, the fire resistance could be compromised and the test result cannot be applied.

The test can be applied to JUMBO® FireWALLS up to 4.2 metres in height.

The following information is available on our website:-

BOQ Specification, Data Sheets, Revit Files and Detail Drawings.